

QWEL™

Intuitive Leak Detection

With Automatic + Remote Water Shut-Off

Complete User Manual

- Installation Guide
- Technical Specifications
- Manual Shutoff Procedure
- Homeowner Guide (On-boarding)
- Bluetooth Mode



Table Of Contents

Inventory	1
Dimensions/Diagram	2
Installing Qwel	3
Manual Shutoff Procedure	5
Technical Specifications	6
Homeowners Guide (On-boarding)	7
Bluetooth Mode	13
Warranty	15
Privacy Policy	17

Dimensions

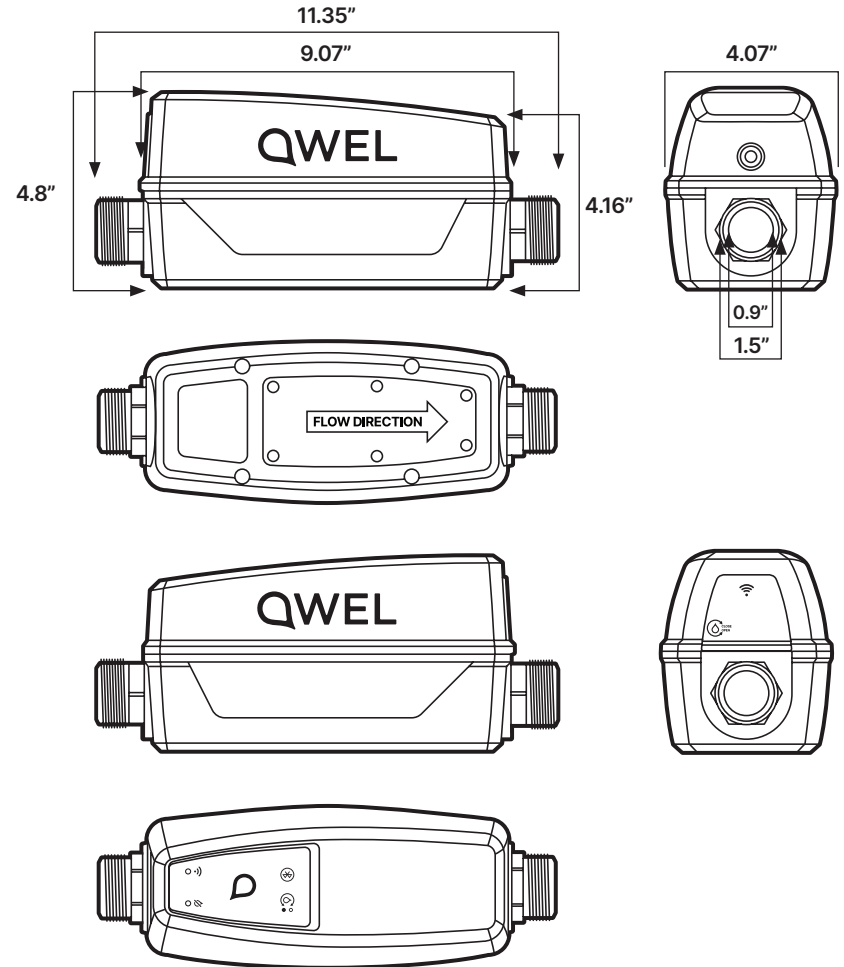

What's in the box?



Qwel Device

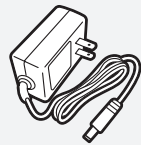

5' Power Supply



1 1/4" NPSM Installation Tube



1 1/4" NPSM to 1" NPT Fitting (x2)



- Pairing Button**
Press to set the unit to Pairing Mode
- Open/Close Button**
Press to open or close the valve
- Valve Status Light**
Green: Valve is open
Red: Valve is closed
Unlit: Unit is not powered
- Pairing Light**
Green: Connected to Bluetooth or Wi-Fi network
Unlit: Not connected to Bluetooth or Wi-Fi network

Installing Qwel

Horizontal installation diagram shown. For a vertical installation, rotate this page 90 degrees counter-clockwise.

IMPORTANT: Qwel should be installed by a licensed plumbing professional. Failure to follow installation instructions may lead to an improperly functioning or leaking device and void manufacturer's warranty. See full warranty terms at <URL>.

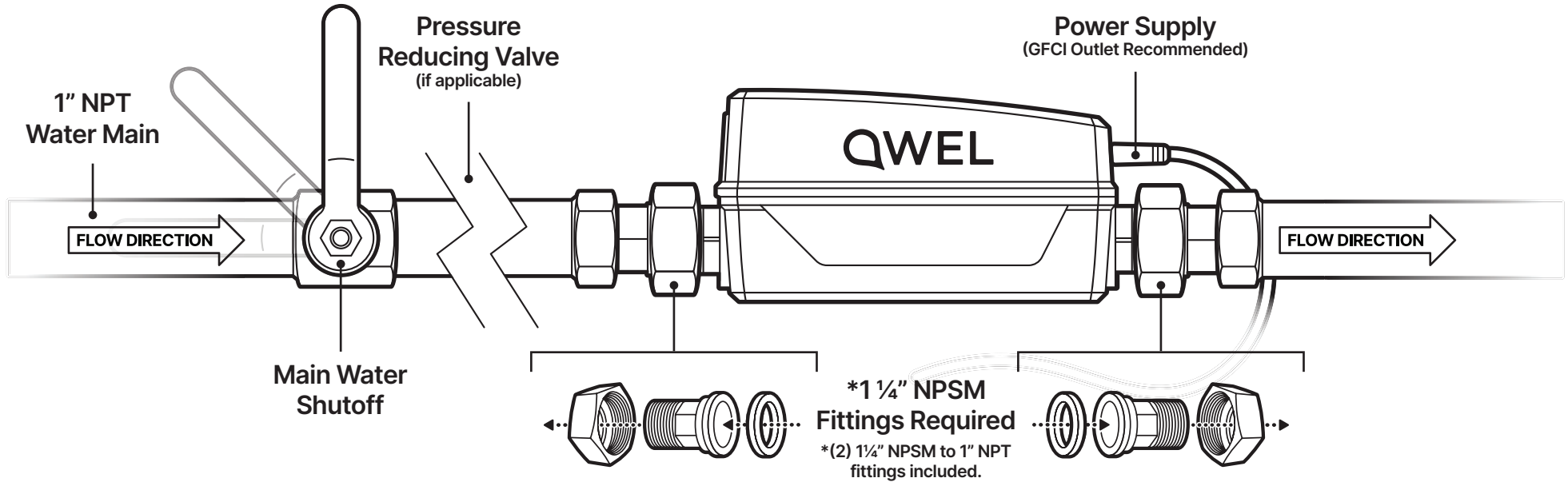

Installation Requirements

- 1 The Qwel device is installed in an accessible location on the main cold water supply line from water provider.
- 2 The Qwel device must be installed **AFTER** water meter, main water shut-off, and pressure reducing valve (if applicable).
- 3 For accurate monitoring and water usage data, your Qwel device must be installed **BEFORE** water heaters, water softeners, whole house filters, etc.
- 4 The power supply and device must not be buried or installed where the ambient temperature can exceed 140 deg F (60 deg C) or below 32 deg F (0 deg C).
- 5 240 VAC-50/60 Hz) with continuous power within 5' of the installation. A GFCI outlet is recommended.
- 6 A smartphone with the Qwel app installed is required to activate your Qwel device, receive notifications, and perform remote water shutoff.
- 7 The device must be in range of a Wi-Fi network (WLAN connectivity / IEEE 802.11 bgn, 2.4 GHz range)

Manual Valve Shutoff Procedure

Close the Qwel Valve Manually:

In the event of a prolonged power outage or other scenario, you can close or open the Qwel valve manually if needed.

Remove the end cap shield to reveal the manual gear access port. Close the valve using a standard flathead screwdriver, turning clock-wise approximately 15 full revolutions. The gear will stop turning when the valve is fully closed.

15x

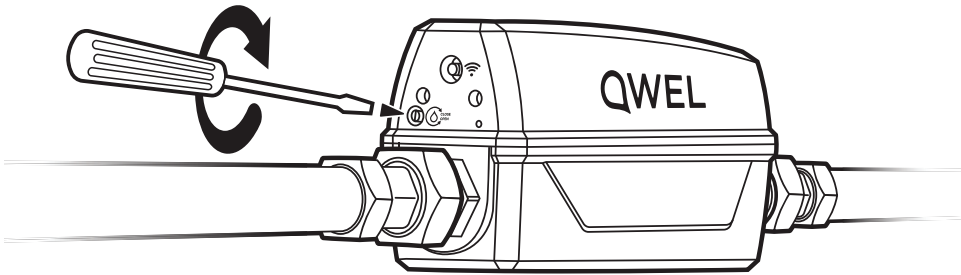

Open the Qwel Valve Manually:

To restore water to the home: Open the valve using a standard flathead screwdriver, turning counter clock-wise approximately 15 full revolutions. The gear will stop turning when valve is fully open. Replace the end cap shield.

15x

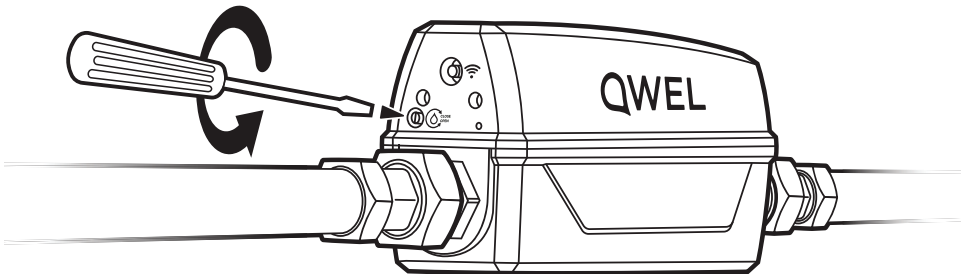

Technical Specifications

Description/Name

Qwel

Location

Indoor

Orientation

Horizontal or vertical

Fitting Size

1" male threaded (NPSM) ends designed to adapt to different fittings and plumbing materials (PEX, copper, PVC, etc...) Compatible with pipe sizes up to 1 1/4" Note: pipe fitting adapters are not included.

Dimensions + Weight

4.8" L x 4" W x 9" H 11.3" Weight: 2.85 lbs

Max PSI

180psi ??????????

Sensors

Proprietary ultrasonic flow sensor
High definition pressure sensor +/-0.5%
Temperature sensor +/- 5°F
Humidity Sensor
TDS Sensor (Water Quality)

Shut-Off Valve

Stainless steel full bore construction
Electronic for remote control
Manual override with standard slotted screwdriver

Wireless

802.11 b/g/n @2.4Ghz

Antenna

Integrated External antenna

Power

110/220V 15W power supply
5 foot power cable
GFCI outlet recommended

AC Power

Input - 110/220 V AC
Output - 5V/3A DC

Features

Leak alert notifications
Automatic + remote water shut-off
Automatic water shut-off customization parameters
Diagnostic Plumbing Checks
Monthly, weekly, hourly water use data
Single device, whole home protection

Connectivity Requirements

Wi-Fi connection
Bluetooth connection (Service Professional Access to Device)
Phone or tablet with iOS 14+, Android 10+
SMS text messaging
Qwel app

Certifications

NSF/ANSI 61: Drinking Water System Components; Health Effects
NSF/ANSI 372: Drinking Water System Components; Lead Content
IP55 rated: Sealed against foreign particles and water
RoHS 2011/65/EU Compliant: Hazardous Substances
HALT tested to Military standard-810G: Heat / UV / Cold / Humidity
State of Massachusetts Plumbing Board Approved
UL 1310/60950
CAN/CSA C22.2

Warranty

2-year limited warranty

Homeowners Guide (Onboarding)

Congratulations on the purchase of your new Qwel device! Qwel is an advanced leak detection and water conservation ecosystem. The Qwel app will prompt you through the onboarding steps but if you need additional assistance, step by step instructions are provided here for completing the process.

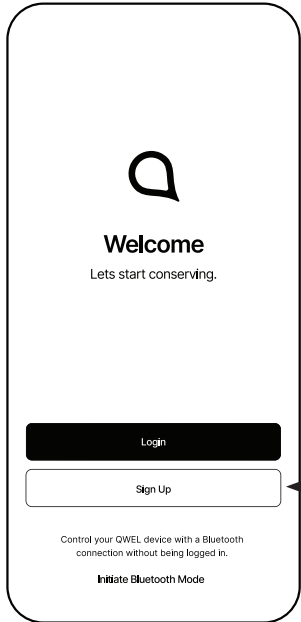

1 Begin by opening the Qwel app (if you already have a Qwel account, skip to step 3). On the splash screen, tap "Sign Up".

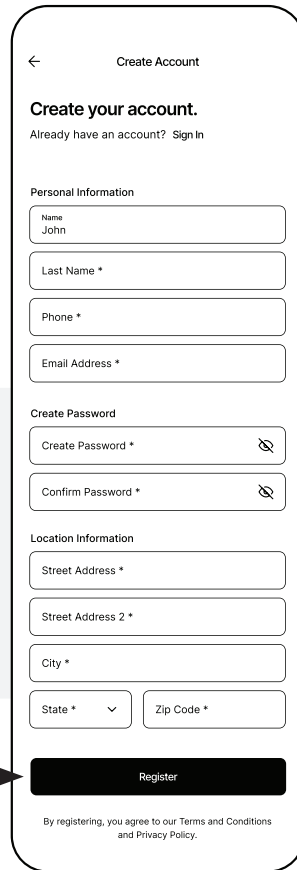

2 Fill all fields on the "Create your account" screen and tap "Register" when finished.

An email will be sent to the email address provided during the signup process. In the email, check the information to ensure everything looks correct. If so, click "verify" to complete the signup process.

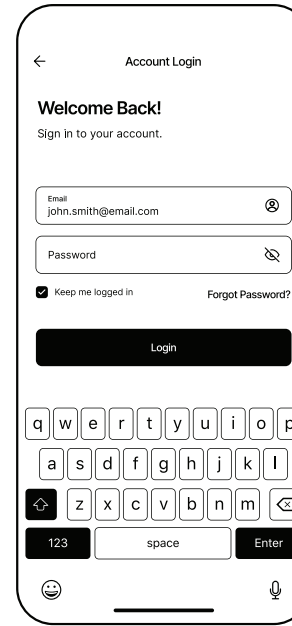

3 From the Qwel app, tap "Login". From the Login screen (Figure 2), enter the email address and password that you chose during the account creation step, then tap "Login". If you select "Keep me logged in", you will not have to enter your login information every time you want to access your Qwel device.

4 Follow the on-screen prompts to add your first location. This information helps the Qwel AI accurately determine when leaks have occurred and is used by the app to provide feedback on your water usage. Be sure that all the information you provide during the location setup is accurate to ensure your Qwel device performs optimally.

You should know the following information about your home:

- Location type
- Qwel install location
- Address
- Location size (in square feet)
- Number of bathrooms
- Number of floors
- Number of people living at the location
- Plumbing information
- Water cost per gallon

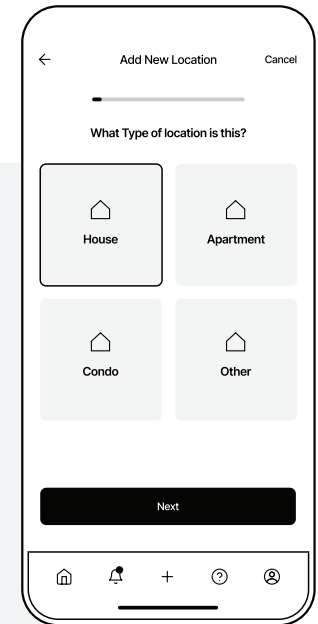

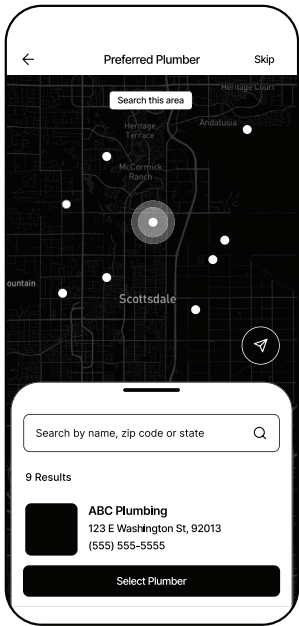

5 The Qwel app can send information on your Qwel system to your Preferred Plumber. This feature makes the process of troubleshooting leaks or other problems quick and easy.

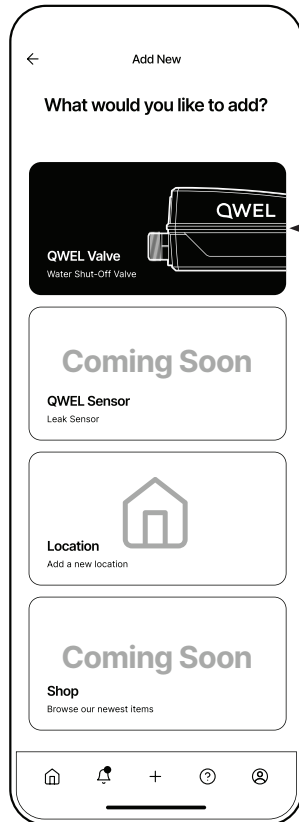

7 Ensure your Qwel device is powered on. If device is not powered, verify that the included AC adapter is connected securely to both the Qwel device and a working outlet.

On the "Add New" screen, select "Qwel Valve"

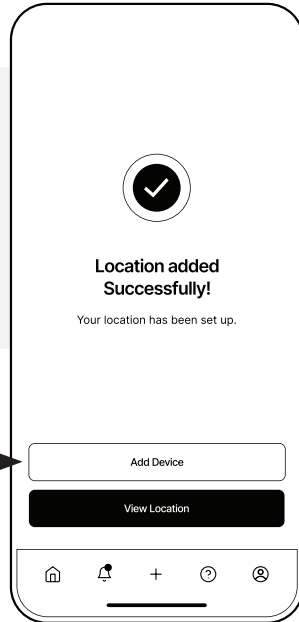

6 Once you have finished creating a location, tap "Add Device" to pair your Qwel device with your account (Figure 4).

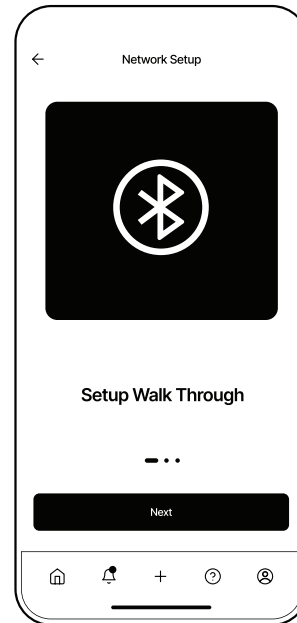

9 On the Network Setup screen (Figure 7), a set of instructions is provided that describes how to enable Bluetooth on your iOS or Android smart phone. Once your phone has Bluetooth enabled, press the "Pair" button on your Qwel device and tap "next" on the Network Setup screen.

10 Select "Qwel Valve" from the list of devices to highlight it, then tap "continue".

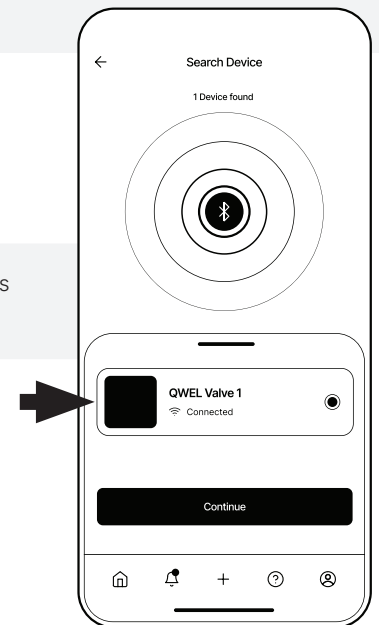

8 Choose the location where you want to add your Qwel device. This should be the location you just created in the previous steps (Figure 6).

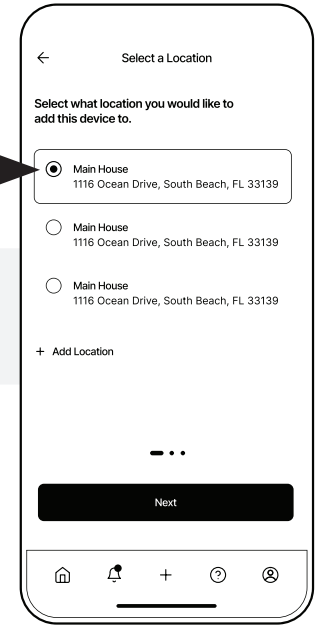

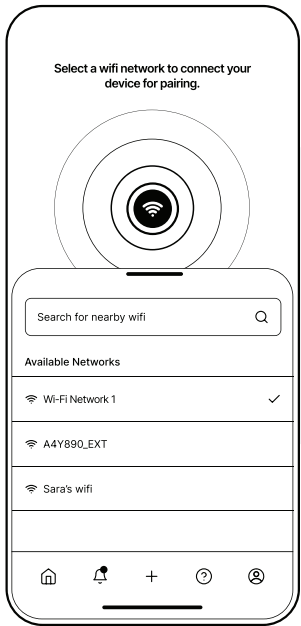

11 Now that your Qwel device is paired with your phone via Bluetooth, select that location's Wi-Fi network from the list. To ensure successful pairing, verify that the network signal is strong near where the Qwel device is installed.

Once you have selected a network, you will be prompted to enter the network password. Enter the network password, then tap "Join".

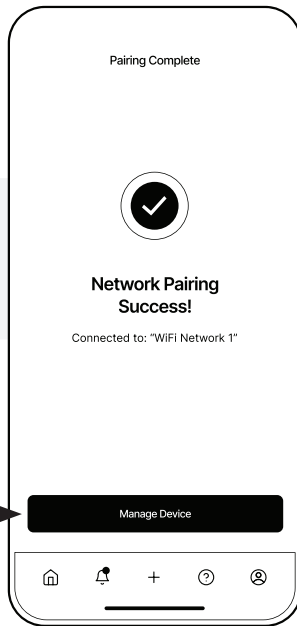

12 If the device connects to the network successfully, you will see a message that says "Network Pairing Success!". Tap "Manage Device" to continue

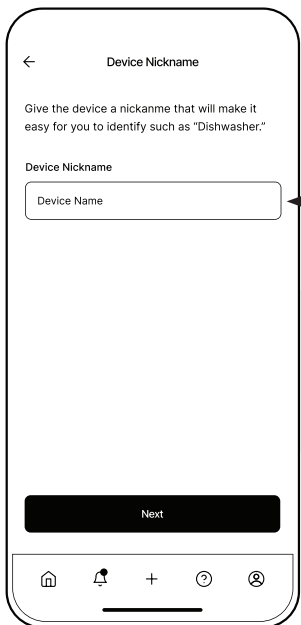

13 Assign your device a nickname by tapping the "Device Name" box. Choose a name that will be helpful to distinguish this device from others in your Qwel Ecosystem at this location.

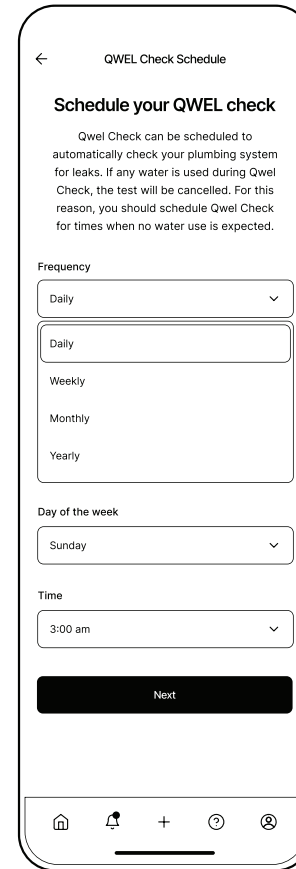

14 Your Qwel device supports periodic testing of your plumbing system's integrity using the Qwel Check feature. This feature is particularly useful for detecting small leaks or dripping fixtures. When Qwel Check runs, the valve on your Qwel device will close automatically and monitor the pressure change in your plumbing system for a period of up to 5 minutes.

Running water on your plumbing system during a Qwel Check will abort the Qwel Check. For this reason, it is recommended to schedule your Qwel Checks during times when no water use is expected at the location where the Qwel device is installed.

By default, Qwel Check is scheduled to run daily at 3:00 AM, but this may not be appropriate for your location.

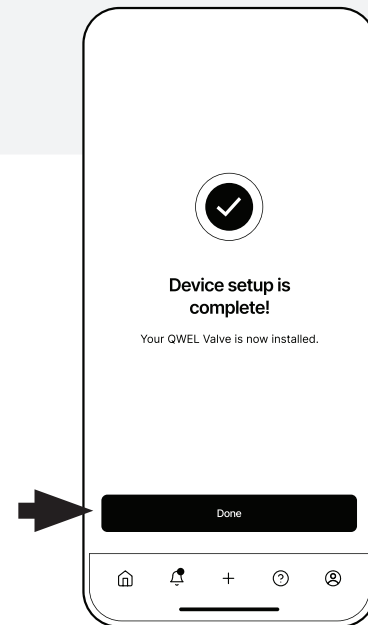

Bluetooth Mode

In situations where a Wi-Fi connection is not available, it is possible to control your Qwel device directly using Bluetooth Mode. Your Preferred Plumber may find Bluetooth Mode useful for quickly troubleshooting the Qwel hardware. In Bluetooth Mode, controls are restricted to:

- Opening and closing the valve
- Running a Qwel Check
- Enabling or disabling the automatic shutoff feature
- Viewing real-time sensor data and device information

To access Qwel in Bluetooth mode:

- 1 Ensure your phone has Bluetooth turned on and that your Qwel device is powered on.

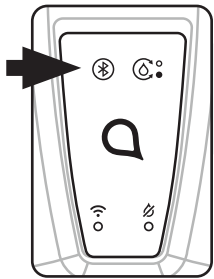

- 2 Press the pairing button on your Qwel device.

- 3 Open the Qwel app. On the splash screen, tap "Initiate Bluetooth Mode" to look for your Qwel device.

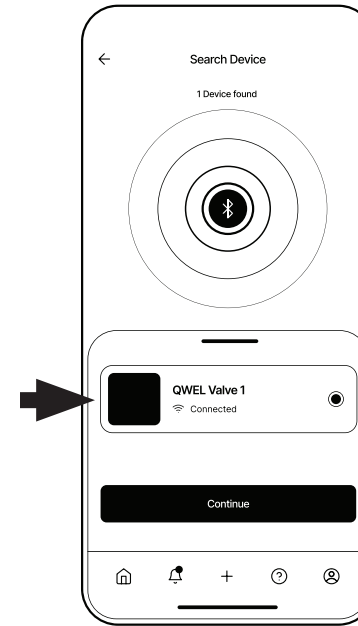
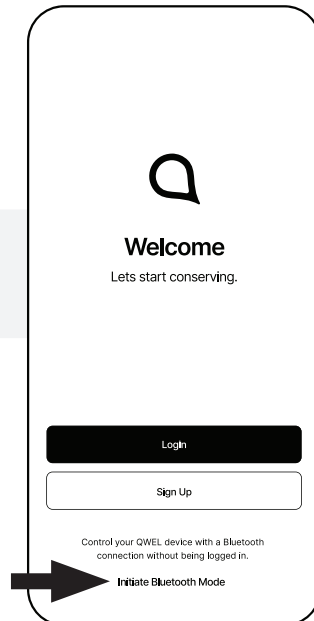

- 4 Tap the entry for your Qwel device. You will see it either as "Qwel" or by the name that you chose during the setup process, then tap "Continue".

- 5 If the connection was successful, you will see the Bluetooth Mode screen. You can access controls for valve operation and automatic shutoff here.

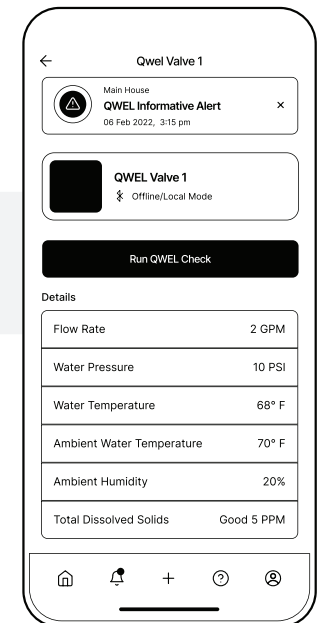

Two (2) Year Limited Warranty

What is covered under this limited warranty (including, if applicable, the Supplemental Warranty as defined and set forth below) (the "Limited Warranty")?

Notation Labs, Inc ("Qwel") warrants to the original purchaser of this Qwel product that, when properly installed, the product will be free from defects in materials and workmanship under normal conditions of use for a period of two (2) years from the date of delivery to the purchaser (the "Limited Warranty Period").

We reserve the right to change the terms of the Limited Warranty at any time so please review this Limited Warranty every time you place an order or otherwise acquire any Qwel product.

What will we do to correct problems

If Qwel determines that the product was installed appropriately and has failed or is defective within the scope of this Limited Warranty, Qwel will, at its option, either (i) repair or replace, free of charge, any defective Qwel product, or (ii) accept the return of the product and refund the money actually paid by the original purchaser for the product. Repair or replacement may be made with a new or refurbished product or component, at Qwel's sole discretion. Qwel reserves the right to discontinue any of its products without notice and disclaims any warranty to repair or replace any such discontinued products. In the event that Qwel is unable to repair or replace a product (for example, because it has been discontinued) covered by the Limited Warranty, Qwel will offer a credit toward the purchase of another Qwel product in an amount equal to the purchase price of the product as discounted. If the product or a component incorporated within it is no longer available, Qwel may, at its sole discretion, replace the product with a similar product of similar function.

This is your sole and exclusive remedy for breach of this Limited Warranty. This Limited Warranty is transferable from the original purchaser to subsequent owners, but the Warranty Period will not be extended in duration or expanded in coverage for any such transfer.

What is not covered by this Limited Warranty

In order for this Limited Warranty to be in effect, the Qwel product must be: (i) installed, maintained, repaired and operated in accordance with the instructions provided by Qwel; (ii) installed in an end-use environment as intended for the product; and (iii) installed in accordance with then-applicable building, mechanical, plumbing, electrical, or other applicable code requirements.

Without limiting the foregoing, this Limited Warranty does not cover and will be voided if Qwel determines that any of the following have occurred: (i) the product was not installed in accordance with the terms of Qwel's Installation Guide or other written instructions provided by Qwel; (ii) the product has been altered or tampered with in any way or improperly handled or maintained; (iii) the product has been exposed to temperatures and/or pressures that exceed the limitations for the product, exposed to highly corrosive atmospheric conditions or subjected to abnormal physical or electrical stress; (iv) the product was installed, handled, or stored not in accordance with instructions provided by Qwel; or (v) the product was combined with any non-Qwel hardware products. This Limited Warranty does not cover data loss related to the Qwel hardware product regardless of the nature or basis of the loss. Products installed on anything other than potable water service lines shall not be covered by this Limited Warranty (for example, irrigation lines or well systems). Unauthorized use of the product or software can impair the product's performance and may invalidate this Limited Warranty.

This Limited Warranty does not protect against, and any liability for losses related to any of the following are hereby expressly excluded; acts of God such as flood, lightning, earthquake, war, vandalism, theft, and does not protect against losses due to normal-use wear and tear, erosion, depletion, obsolescence, abuse, damage due to low-voltage disturbances (i.e., brownouts or sags), non-authorized program, inadequate connectivity of the Qwel hardware product to wi-fi networks or otherwise, wi-fi throughput below required levels, or system equipment modification.

In addition, Qwel does not give any warranty: (i) in relation to software or services provided or made available by Qwel with the product, whether factory loaded on the product, contained on media accompanying the product, or downloadable in connection with the product; (ii) in relation to any third-party software or service offerings which may be included in, accessible by, or bundled with the product; (iii) that the operation of the Qwel product, software, or services will be uninterrupted or error free; (iv) that the Qwel product, software or services, or any equipment, system or network on which the product, software or services are used, will be free of vulnerability to intrusion or attack; or (v) as to the continued availability of a third party's service which this product's use or operation may require.

Warranty replacement or deposits may be subject to a restocking fee of up to 20% of the purchase price, plus any applicable sales tax, unless the product is defective or the return is a result of a Qwel error. Details for any deduction will be shown on your confirmation email for the return.

30-day return policy

If you are the original purchaser of the product, purchased through Qwel directly, and you wish to return the product for any reason, you may return it in its original condition within thirty (30) days of the original purchase and receive a full refund. If the product was installed or has been used in any way then it is not eligible for the refund.

Your refund will be initiated once we receive and inspect your return. Please allow us up to 15 business days to complete inspection. Once completed, you will receive email confirmation of your refund.

Qwel may deny refund or exchange for any returns that have been tampered with, have missing parts, have been misrepresented and/or are not received and inspected by our warehouse.

Original shipping and handling charges may not be refunded.

The product should be shipped in an outer box for protection and contain a note with the Order number, contact information,

and reason for the return.

We can only issue refunds back to the original form of payment. To receive a complete refund, all items from the original purchase must be returned.

If you financed your purchase, refunds will not include any interest due on the loan or any of the non-refundable amounts described above, and you will remain responsible for the performance of your financing agreement.

Return refunds may be subject to a restocking fee of up to 15% of the purchase price, plus any applicable sales tax, unless the product is defective or the return is a result of a Qwel error. Details for any deduction will be shown on your confirmation email for the return.

If you have met all the requirements of 30-day return policy and wish to return your Qwel product(s) then please contact Qwel at store@Qwel.com for instructions on returning your device. Please include Order number, complete contact information and the reason for the return. Qwel will not accept returns if it is outside of the 30-day policy.

How to get service for your Qwel product warranty

1. Contact Qwel by calling (877) 749-6792, or go to Qwel.com/help-center within 5 days of recognizing a defective Qwel product within the Limited Warranty Period

IMPORTANT: When submitting a claim under this Limited Warranty be prepared to provide the following information:

The part number of the Qwel product (printed physically on the device).

MAC address (printed on the label attached to the blue customer quick start guide).

Copy of the original receipt

2. A Qwel customer service representative will provide the information on how to proceed with your claim.

Qwel reserve the right to review the damaged Qwel product. The damaged product must remain available for inspection until the claim is finalized. Whenever claims are settled, Qwel reserve the right to be subrogated under any existing insurance policies the purchaser may have.

Any product that has either been repaired or replaced under this limited warranty will be covered by the terms of this limited warranty for the longer of (a) ninety (90) days from the date of installation of the repaired product or replacement product, or (b) the remainder of the Limited Warranty Period.

Qwel will not provide any warranty coverage unless your claim is made in compliance with all terms of this Limited Warranty as set forth above.

Exclusions and disclaimers under this Limited Warranty

This Limited Warranty gives you specific legal rights, and you may also have other rights, which may vary from state to state. Some states do not allow the exclusion or limitation of incidental, consequential, or other damages, so the above limitations may not apply to you. The terms of this Limited Warranty will apply to the extent permitted by applicable law. For a full description of your legal rights you should refer to the laws applicable in your jurisdiction and you may wish to contact a relevant consumer advisory service.

EXCEPT AS PROVIDED IN THIS LIMITED WARRANTY AND TO THE MAXIMUM EXTENT PERMITTED BY APPLICABLE LAW, IN NO EVENT SHALL QWEL, OR THEIR AFFILIATES, OR THEIR RESPECTIVE OFFICERS, DIRECTORS, EMPLOYEES, LICENSORS AND ASSIGNS, BE LIABLE FOR ANY DIRECT, INDIRECT, EXEMPLARY, PUNITIVE, SPECIAL, INCIDENTAL, OR CONSEQUENTIAL DAMAGES WHATSOEVER (INCLUDING BUT NOT LIMITED TO DAMAGES FOR LOSS OF PROFITS OR REVENUE, FOR DAMAGE TO REAL OR PERSONAL PROPERTY, FOR BUSINESS INTERRUPTION, FOR PERSONAL INJURY, FOR LOSS OF PRIVACY, FOR LOSS OF ABILITY TO USE ANY THIRD-PARTY PRODUCTS OR SERVICES, FOR FAILURE TO MEET ANY DUTY INCLUDING OF GOOD FAITH OR OF REASONABLE CARE, FOR NEGLIGENCE, AND/OR FOR ANY OTHER PECUNIARY OR OTHER LOSS WHATSOEVER), REGARDLESS OF THE THEORY OF LIABILITY (CONTRACT, TORT, OR OTHERWISE), ARISING OUT OF OR IN ANY WAY RELATED TO THE USE OF OR INABILITY TO USE THE PRODUCT, EVEN IF QWEL, OR THEIR AFFILIATES HAVE BEEN ADVISED OF THE POSSIBILITY OF SUCH DAMAGES. THIS LIMITATION IS CUMULATIVE AND WILL NOT BE INCREASED BY THE EXISTENCE OF MORE THAN ONE INCIDENT OR CLAIM. THE FOREGOING LIMITATIONS WILL APPLY EVEN IF ANY WARRANTY OR REMEDY PROVIDED FAILS OF ITS ESSENTIAL PURPOSE. NOTHING HEREIN SHALL LIMIT THE LIABILITY OF QWEL IN RELATION TO DEATH OR BODILY INJURIES.

THE WARRANTIES AND REMEDIES SET OUT IN THIS LIMITED WARRANTY ARE EXCLUSIVE AND, TO THE EXTENT PERMITTED BY LAW, IN LIEU OF ALL OTHERS, WHETHER ORAL OR WRITTEN, EXPRESS OR IMPLIED.

IN THOSE JURISDICTIONS WHERE IT CAN LAWFULLY DO SO, AND TO THE MAXIMUM EXTENT PERMITTED BY APPLICABLE LAW, QWEL AND THEIR AFFILIATES HEREBY DISCLAIM AND EXCLUDE ALL OTHER WARRANTIES, EXPRESS, STATUTORY, OR IMPLIED, INCLUDING, BUT NOT LIMITED TO, IMPLIED WARRANTIES OF MERCHANTABILITY, ACCEPTABILITY, SATISFACTORY QUALITY, NON-INFRINGEMENT, TITLE, FITNESS FOR A PARTICULAR PURPOSE, LOSS OF OR DAMAGE TO DATA, LACK OF VIRUSES OR FREE FROM VIRUS OR MALWARE ATTACK, SECURITY, PERFORMANCE, LACK OF NEGLIGENCE, WORKMANLIKE EFFORT, QUIET ENJOYMENT, THAT THE FUNCTIONS CONTAINED IN THE PRODUCT WILL MEET YOUR REQUIREMENTS, OR THAT DEFECTS IN THE PRODUCT WILL BE CORRECTED, OR THAT YOUR USE OF THE PRODUCT WILL GENERATE ACCURATE, RELIABLE, TIMELY RESULTS, INFORMATION, MATERIAL, OR DATA. THE ONLINE SERVICES INTENDED TO OPERATE WITH THE QWEL PRODUCTS PROVIDE USERS WITH CERTAIN INFORMATION. ALL SUCH INFORMATION IS PROVIDED "AS IS" AND "AS AVAILABLE". QWEL DOES NOT WARRANT OR GUARANTEE THAT SUCH INFORMATION WILL BE AVAILABLE, ACCURATE, OR RELIABLE OR THAT USE OF SUCH INFORMATION, SUCH ONLINE SERVICES, OR QWEL PRODUCTS WILL FULLY PROTECT REAL PROPERTY FROM WATER DAMAGE. NO ORAL OR WRITTEN INFORMATION OR ADVICE GIVEN BY QWEL, OR A DEALER, RESELLER, AGENT, REPRESENTATIVE, OR AFFILIATE OF QWEL SHALL CREATE A WARRANTY. TO THE EXTENT WARRANTIES CANNOT BE DISCLAIMED OR EXCLUDED, THEY ARE LIMITED TO THE DURATION OF THE RELEVANT EXPRESS WARRANTY PERIOD.

Some states do not allow limitations on how long an implied warranty lasts, so the above limitations may not apply to you.

Limitations on liability under this Limited Warranty

TO THE MAXIMUM EXTENT PERMITTED BY APPLICABLE LAW, THIS LIMITATION SHALL APPLY TO ANY AND ALL DAMAGES, REGARDLESS OF THE LEGAL THEORY ON WHICH THEY ARE ASSERTED (INCLUDING, WITHOUT LIMITATION, CONTRACT, BREACH OF CONTRACT OR TORT), AND REGARDLESS OF WHETHER Qwel HAS BEEN ADVISED OF THE POSSIBILITY OF LOSS OR DAMAGES (UNLESS YOU PROVE THAT Qwel CAUSED DAMAGES TO YOU INTENTIONALLY). TO THE MAXIMUM EXTENT PERMITTED BY APPLICABLE LAW, THE AMOUNT OF Qwel'S TOTAL CUMULATIVE LIABILITY ARISING FROM OR RELATED TO THIS LIMITED WARRANTY OR THE PRODUCT WILL NOT EXCEED THE TOTAL PRICE ACTUALLY PAID FOR THE PRODUCT BY THE ORIGINAL PURCHASER. THIS ALLOCATION OF RISK IS REFLECTED IN THE PRICE CHARGED FOR THE PRODUCT AND SERVICES, IF ANY. YOU ACKNOWLEDGE THAT THE PRICE OF THE PRODUCT AND SERVICES WOULD BE MUCH GREATER IF Qwel UNDERTOOK MORE EXTENSIVE LIABILITY.

Qwel Privacy Policy

We at Qwel are committed to protecting your privacy. Our goal is to provide you with a positive experience on our websites and when using our apps, products and services, while at the same time keeping your Personal Information, as defined below, secure. Our privacy practices are described below, as well as in separate notices given when an app, product or service is purchased or downloaded (our "Privacy Policy").

For ease of reference, we will use the following terms in this Privacy Policy:

"Qwel", "our", "us" or "we" means Qwel, LLC and Qwel Oy, including their affiliated companies.

"Qwel Products" includes all Qwel-branded apps, products and services.

"Qwel Websites" include all global Qwel websites.

This Privacy Policy covers all Qwel Products and Qwel Websites. By visiting Qwel Websites, using Qwel Products or providing us with your Personal Information (as defined below), you are accepting and consenting to the practices, terms and conditions described in this Privacy Policy, the terms of which you acknowledge you have read and understood. If you are visually impaired, you may access this notice through your browser's audio reader.

If you are in the EEA, for the purposes of the EU General Data Protection Regulation 2016/679 ("GDPR"), the data controller is Qwel LLC of Qwel c/o Belkin International, 555 Aviation Blvd, Ste. 180, El Segundo, CA 90245

TYPES OF INFORMATION COVERED BY THIS PRIVACY POLICY

Personal Information. This means any information that (either in isolation or in combination with other information) can be used to identify you directly or indirectly. Some examples of Personal Information include your name, address, email address, phone number, any ID number or location data.

Aggregated Information. Information may be aggregated and/or anonymized. When information is aggregated, it is combined with information about other customers and users. Aggregated information that includes Personal Information is considered Personal Information until it has been anonymized.

Anonymized Information. When information is anonymized, Personal Information is removed from collected data and the remaining portion of the data is repurposed for internal or external use, such as, for example, to determine how many users of Qwel Products had a water leak in the past year, or how many users viewed a particular website video or advertisement. Anonymized information cannot be used to identify you.

Children's Personal Information. The Qwel Websites and Qwel Products are not directed to, nor does Qwel knowingly collect Personal Information from, children under the age of 16. If we are informed that we have collected the Personal Information of a child under the age of 16, we will delete that Personal Information from our systems. If you believe we might have inadvertently collected Personal Information from or about a child under the age of 16, please contact us at info@Qwel.com. We also do not sell the information of minors under the age of 16 years of age.

HOW WE COLLECT INFORMATION

We collect and process the following data about you:

Information you give us. If you fill in forms on Qwel Websites or correspond with us by phone, email or otherwise, you may be providing us with information about you, which may include Personal Information. This includes information you provide when you register on Qwel Websites, register or return a Qwel Product, subscribe to any of our services, search for a product, place an order on Qwel Websites, participate in social media functions on Qwel Websites, enter a competition, promotion or survey, participate in a training session or other event, download firmware, software and apps, or when you report a problem with Qwel Websites or Qwel Products or otherwise request support. Personal Information you give us may include your name, home address, email address, password, phone number and other contact information, plumbing fixture inventory, Wi-Fi and other home network information, financial and credit card information and any other information that can be used to personally identify you.

Setup information: When you install the Qwel device, you'll be asked to provide information to set up your account. You will also be asked to provide an inventory of the plumbing fixtures in your home to allow Qwel to understand the normal water usage patterns in your home to detect leaks and quantify your water usage.

Mobile Phone Number: When you create a Qwel account, you will be asked to provide your mobile phone number in order to

verify your identification. Once you provide this phone number, it will be stored along with your account information and will be used to send you SMS alerts regarding various functions of the service, including alerts about leaks, alerts about device connectivity and alerts about product enhancements, such as when new functionality has been unlocked for your account.

Profile Information: Your account may allow you to provide certain basic profile information like your name and profile photo. Names and profile photos may be shown to others in connection with the Services. For example, if you invite someone as an additional authorized user, he or she may be able to see your name and photo. You should only use photos you are willing to make public.

Information we collect about you. We automatically collect information when you use Qwel Websites or Qwel Products, including:

Data from your Qwel Product's sensors, including but not limited to alerts, notifications, user preferences, settings, and user actions, water usage information (including current flow rate, temperature and pressure rate) other data collected by Qwel via third party systems you've authorized Qwel to communicate with, and direct adjustments to your Qwel Product and Qwel app, including modifications or settings. We will also collect information as you use and interact with Qwel, including your activity using the Qwel app, clicking on the various functions and features and providing feedback from alerts and water consumption data to correct the system. This data helps your Qwel Product detect leaks. Information about leaks, notifications or alerts delivered through the Qwel app, and any actions you take in response to those notifications are also collected and used to improve the system's ability to detect leaks and quantify water use.

Technical information from the Qwel Product: In order to improve your experience over time and help troubleshoot any problem you may encounter with the Qwel Product, we record your device's model and serial number, software version, and other technical information.

Wi-Fi Network Information: To connect your Qwel Product to our app and services, or to access your Qwel Product over the Internet from a computer, a smartphone or a tablet, you will need to connect it to your Wi-Fi network. During setup, Qwel will ask for your Wi-Fi network name (SSID) and password to connect to the Internet. It will save this information on the Qwel Product firmware, along with your IP address, so that you can access it and control it from your computer, smartphone or tablet, and so that it can communicate with Qwel's servers and download software updates. Once connected to your Wi-Fi network, your Qwel Product regularly sends the data described in this Privacy Policy (excluding your Wi-Fi password) to Qwel to provide you with services related to your water use.

Information about your visit to Qwel Websites, including the full Uniform Resource Locators ("URL") you clickstream to, through and from Qwel Websites (including date and time), products you viewed or searched for, page response times, download errors, length of visits to certain pages, videos watched, page interaction information (such as scrolling, clicks, and mouse-overs), and methods used to browse away from the page.

Information we receive from other sources. We may also receive information about you from other sources, including third parties who provide services to us (including, for example, business partners, our affiliates, subcontractors in technical, payment and delivery services, advertising networks, analytics providers, search information providers, credit reference agencies or publicly available sources) and we may receive information about you from them.

HOW WE USE INFORMATION

We use the information we collect for a number of purposes. These purposes will be consistent with the reason you provided the information to us or for a directly related purpose. The uses we make of such information include the following:

To set up an account for you on Qwel Websites or Qwel Products.

To facilitate your purchase and/or download of Qwel Products.

To authenticate use of your account or purchases and/or use of a Qwel Product.

To register your Qwel Product in our product database.

To carry out our obligations arising from any contracts entered into between you and us and to provide you with the information, products and services that you request from us.

To assist you with customer support.

To communicate about and administer participation in customer promotions and surveys you choose to participate in.

To provide the Qwel Products or any services you request.

To provide you with information about the Qwel Products you use, such as new features, bug fixes, service downtimes or upgrades.

To provide you from time to time with information relating to your energy or water usage and suggest potential savings in water or energy usage, including making assessments and recommendations about your plumbing, water leaks and water use.

To help us develop new Qwel Products and services and improve current Qwel Products and services.

To provide you, or permit selected third parties to provide you, with information about goods or services we feel may interest you. We (or selected third parties) will contact you by electronic means only if you have opted-in to receive marketing information. "Opt-in" means that you have taken an affirmative action to receive information, such as by checking a box or clicking a button.

To notify you about changes to Qwel Websites and Qwel Products and changes to our terms, conditions and policies.

To administer Qwel Websites and Qwel Products for internal operational purposes, including troubleshooting, data and statistical analysis, testing, research and survey purposes.

To improve Qwel Websites and Qwel Products and to ensure that content is presented in the most effective manner for you and for your computer or device.

To ensure the security of Qwel Websites and Qwel Products.

To monitor and regulate interactive features of Qwel Websites and Qwel Products that you may choose to participate in.

To help you navigate Qwel Websites.

To help you access and use certain features of Qwel Products remotely and to help you monitor and safeguard your home.

To measure or understand the effectiveness of advertising we serve to you and others who visit Qwel Websites and to deliver relevant personalized advertising to you and others.

To determine which aspects of Qwel Websites and Qwel Products are most useful to you and other users of Qwel Websites and Qwel Products.

Why We Use Information

Where we process your Personal Information to provide a product or service, we do so because it is necessary to perform

contractual obligations that we owe to you. If you choose not to provide us with the Personal Information we need to provide you with a product or service, we will not be able to provide the product or service to you. When you purchase and/or download new Qwel products, we will only use your Personal Information for the purposes set out in this Privacy Policy, and any notification provided to you at the time of purchase or download.

We also use your Personal Information to protect our business (for example, against fraud), to comply with legal requirements to which we are subject (for example, tax or financial reporting requirements) and for other legitimate interests.

We will send you direct marketing only if you have given your consent to such communications. See the Marketing section below.

SHARING INFORMATION

Under no circumstances do we rent or sell your Personal Information. We will only share your Personal Information with third parties for marketing purposes if you have granted us permission to do so and in accordance with the Marketing section below. We share Personal Information in the following ways:

Within Qwel for purposes of data processing or storage.

Within Qwel's corporate group, including with our subsidiaries, affiliated companies and divisions, all of whom may use your information for the purposes disclosed in this Privacy Policy.

With Qwel's service providers. Our service providers are not allowed to use, share or retain your personal information except as permitted by us.

With other third parties with your consent. Qwel may provide you with the ability to enable authorized users ("Authorized Users") to access your account. Information will only be shared with Authorized Users if you give explicit consent to this sharing. If you consent, the Authorized Users may control and view all of your devices, content, and third-party connections. One example of an Authorized User would be if you invite another person to access your Qwel account as an Authorized User. An invited user must have or create a Qwel account, and information about invited users (like email address, name, or changes to product settings) will be stored with your account. Another example would be if you sign up for programs offered by our partners (such as insurance companies); if you do this, we may share certain information with the partner. This could include your enrollment information, usage data and the activation status of your device. Usage data received through Qwel sensors may be shared with Authorized Users if you authorize them to receive such data (such as your plumber, property owner/manager or insurance company). Similarly, when you connect third-party devices and services to your Qwel Products, you are shown information about any proposed exchange of data. Your explicit consent is required to allow these exchanges on your behalf and you can change your mind at any time.

With service providers, advisors or other third parties to the extent reasonably necessary to proceed with the negotiation or completion of a merger, acquisition or sale of all or a portion of our assets. If Qwel merges with or acquires or is acquired by another entity, Personal Information would be transferred as a whole to the successor entity.

To comply with the law or legal process (such as responding to subpoenas or court orders), to comply with government reporting obligations and to exercise our legal rights or defend against legal claims.

To protect our legal rights or those of others, such as protecting the Qwel brand or investigating violations of Qwel terms of use, violations of law, intellectual property infringement, misuse of Qwel Websites, fraud or potential threats to personal safety.

To the public with your consent, such as when you participate in a survey or review.

In addition, we may use and share aggregated and anonymized information with third parties and service providers for a variety of purposes, including to analyze trends about water usage across all Qwel user homes, to show third parties how their products could work with Qwel Products and to help us make sales, marketing and business decisions. This aggregated and anonymized information may also be shared with other users to help them better understand their water usage compared to other Qwel users, to raise awareness about safety or conservation issues, or to help us generally improve our service. We may also share aggregated and anonymized information with our business partners, for example, if they are interested in providing demand-response services or other incentive programs. We've taken steps to ensure that this information cannot be linked back to you and we require third parties to keep all shared information in its anonymized form.

For certain Qwel Products, Qwel may provide the opportunity for you to connect and interface Qwel Products with one or more third party products and services, which will involve the exchange of information from your Qwel Product with the third-party product or service. Your explicit consent and authorization will be required at the time of connection to the third-party product or service and will be revocable by you at any time by sending us an email request at info@Qwel.com. In some cases, if you purchase, use or download a third-party product or service that connects to a Qwel Product, that third party may apply its own privacy practices. Qwel is not responsible for the privacy practices of third party partners. If you access a Qwel Product through a third-party product in this manner, you consent and agree to the privacy policy of such third party. We encourage you to carefully read the privacy policies and terms of use of any third-party products that connect to Qwel Products before providing them with your Personal Information.

Any service providers with whom we share your Personal Information are required to maintain the confidentiality of the information and are prohibited from using it for any other purpose. We will take all reasonable steps to make sure these service providers comply with the same privacy principles that govern our collection of your Personal Information.

We will ask for your consent, such as by email response, opt-in box or click through agreement acceptance, before we use or share your Personal Information for any other purpose.

MARKETING

We will process your Personal Information for marketing purposes, either from ourselves or a third party, only with your consent.

You have various choices in relation to your Personal Information. Some choices are presented up front in the form of opt-in notices or acceptance boxes for marketing to you or sharing your Personal Information with third parties. You always have the choice to opt-out if you later change your mind. One form of opt-out is clicking the Unsubscribe link in a marketing email. This will take you off our marketing email list.

Please note that these opt-in/opt-out choices do not apply to the receipt of mandatory website, service or software

communications, such as update or downtime information, leak alerts or service integrated emails or receipt of order or shipping confirmations on Qwel Website stores, which you may receive periodically as part of Qwel performing its contract with you, unless you cancel your service or order or terminate use of software in accordance with the applicable terms of use or license agreement.

If you do not wish to receive direct marketing material from us or a third party, in addition to following the "Unsubscribe" instructions in a marketing email, you can send us an email request at info@Qwel.com.

WHERE WE STORE YOUR INFORMATION

The data that we collect from you may be transferred to, and stored at, various locations globally, including the United States. It may also be processed by Qwel staff or contractors operating outside your country of residence (including, if you are in Europe, outside of the EEA, or, if you are in Australia or New Zealand ("ANZ"), outside of ANZ) who work for us or for one of our suppliers. Such staff may be engaged in, among other things, the fulfillment of your order, the processing of your payment details or the provision of support services. We also use cloud-based applications and services to store and process your Personal Information, which may result in your Personal Information being stored outside your country of residence (or the EEA or ANZ).

We will take such steps as are reasonable to make sure we and our service providers do not breach the privacy principles that govern our collection of your Personal Information and that your Personal Information is treated securely and in accordance with this privacy policy as well as applicable data protection laws. By providing your Personal Information to us, you fully understand that Qwel will transfer, process and store your Personal Information outside of your country of residence where data protection standards may be different, and disclose your Personal Information to overseas service providers who may not fully comply with the particular laws of your country.

Our Privacy Policy and our practices are designed to provide a globally consistent level of protection for Personal Information all over the world. This means that even in countries whose laws provide for less protection for your information, Qwel will still handle your information in the manner described in this Privacy Policy and in conformity with all applicable laws. This includes, where relevant, entering into EU standard contractual clauses (or equivalent measures) with the party outside the EEA (available here).

UPDATING YOUR PERSONAL INFORMATION

We need your help in keeping your Personal Information accurate and up to date, so please notify us of any changes to your Personal Information. You can access and update your Personal Information and communication preferences at any time in the following ways:

By clicking the "Unsubscribe" link in any email you receive from us.

By sending an email to info@Qwel.com. Please be sure to include your name, email address and specific relevant details about the information you would like to change or the material that you no longer wish to receive.

For many Qwel Websites and Qwel Products, by signing in to your online account located at the URL provided when you signed up for the Qwel Website or service.

YOUR RIGHTS

You have a number of rights in relation to your personal data. These can differ by country and jurisdiction. You may have the following rights:

The right to receive confirmation as to whether or not we are processing your Personal Information.

The right to correct your data if it is inaccurate or incomplete.

The right to transfer Personal Information you have provided to us to a third party if we are processing that data on either the basis of your consent or to perform a contract with you.

The right to delete your Personal Information, unless we are required to retain it by law or to establish, exercise or defend legal claims, or for another one of our business purposes.

The right to receive a copy of Personal Information held on our current records, as well as information regarding the purposes of the processing, the categories of data involved, to whom such information may be disclosed and for what period we envisage holding the data. If you are outside the EEA or California, we may make a reasonable charge if records must be accessed from backed up or archived records. Note that California residents may be entitled to ask us for a notice describing what categories of personal information (if any) we share with third parties or affiliates for direct marketing.

The right to be informed of the source of the Personal Information, if we did not obtain it from you.

The right to be informed of the appropriate safeguards implemented in relation to any transfer of your Personal Information from within to outside the EEA.

If you are resident in the EEA, you also have the following rights:

The right to withdraw your consent to our processing of your Personal Information at any time after you have consented, including opting-out of receiving marketing materials. The easiest way to do this is by clicking the "Unsubscribe" link in any email you receive from us.

If we are processing your Personal Information either on the basis of your consent or to perform a contract with you, the right to receive such data in a machine-readable format or where feasible to have us transfer it directly to a third party data controller. The right to restrict our processing of your Personal Information where you believe such data to be inaccurate, our processing to be unlawful, or that we no longer need to process such data for a particular purpose (unless we are not able to restrict such processing or delete the data due to a legal or other obligation or because you do not wish for us to delete it).

The right to object to such processing on grounds relating to your particular situation, where the legal justification for our processing of your Personal Information is our legitimate interest. We will abide by your request unless we have compelling legitimate grounds for the processing which override your interests and rights, or if we need to continue to process the data to establish, exercise or defend legal claims.

You can make a request to exercise any of these rights in relation to your Personal Information by sending the request by email to info@Qwel.com or, if you are in California, by calling us at 877-460-2323.

